

Peak Fitness

OWNER'S MANUAL PF-XT1

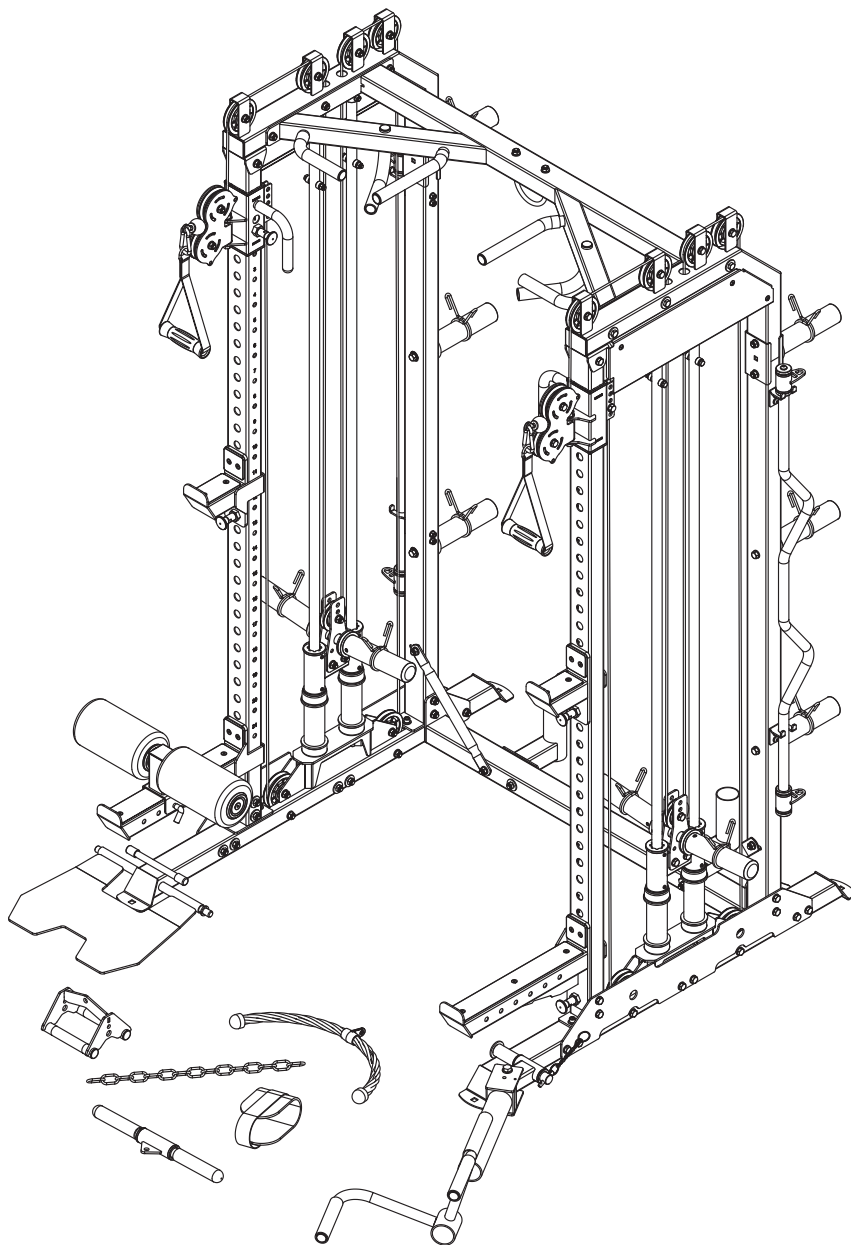

OBS!

Læs alle forholdsregler og instruktioner i denne vejledning, før du bruger dette udstyr.

20230926-V1.0

INDHOLD:

Bør du starter.....	1
Sikkerhedsmeddelelse.....	2
Indhold:.....	4
Samlevejledning:.....	6
Split.tegning.....	19
Parts List.....	20

Før du starter

Tak fordi du valgte Peak Fitness XT1 All-IN-ONE TRAINER.
For din sikkerhed og fordel, læs dette manual omhyggeligt.

Sikkerhedsmeddelelse

Denne træningsmaskine er bygget til optimal sikkerhed. Der gælder dog visse forholdsregler, når du betjener et træningsredskab.

Sørg for at læse hele manualen, før du samler eller betjener din maskine.

Bemærk især følgende sikkerhedsforanstaltninger:

1. Hold altid børn og kæledyr væk fra maskinen. **Lad være med at efterlade børn uden opsyn i samme rum med maskinen.**
2. Kun én person ad gangen bør bruge maskinen
3. Hvis brugeren oplever svimmelhed, kvalme, bryst smerter eller andre unormale symptomer, STOP træningen med det samme.
KONSULTER STRAKS EN LÆGE.
4. Placer maskinen på en jævn vandret overflade.
BRUG IKKE maskinen i nærheden af vand eller udendørs.
5. Hold hænderne væk fra alle bevægelige dele.
6. Brug altid passende træningstøj, når du træner.
7. Løb eller aerobic sko er også anbefalet, når du bruger maskinen.
8. Brug kun maskinen til dens tilsigtede brug som beskrevet i denne vejledning.
9. Brug IKKE tilbehør, der ikke er anbefalet af producenten.
Anbring ikke skarpe genstande omkring maskinen.
10. Handicappede personer bør ikke bruge maskinen uden en kvalificeret person eller læge til stede.
11. Brug ikke maskinen, hvis maskinen ikke fungerer korrekt.
12. En "spotter" er anbefalet under træningen.
13. **Denne maskine er designet til hjemmetræning for private. Den er ikke designet til kommercielt brug.**

ADVARSEL:

FØR DU BEGYNDER ET TRÆNINGSPROGRAM, SØG DIN LÆGE. DETTE ER SÆRLIG VIGTIGT FOR PERSONER OVER 35 ALDER ELLER PERSONER MED EKSISTERENDE SUNDHEDSPROBLEMER.

LÆS ALLE INSTRUKTIONER, FØR DU BRUGER ETHVERT FITNESSUDSTYR. VI PÅTAGER SIG INTET ANSVAR FOR PERSONSKADE ELLER EJENDOMSSKADE OPHOLDT AF ELLER VED BRUGEN AF DETTE PRODUKT.

GEM DISSE INSTRUKTIONER.

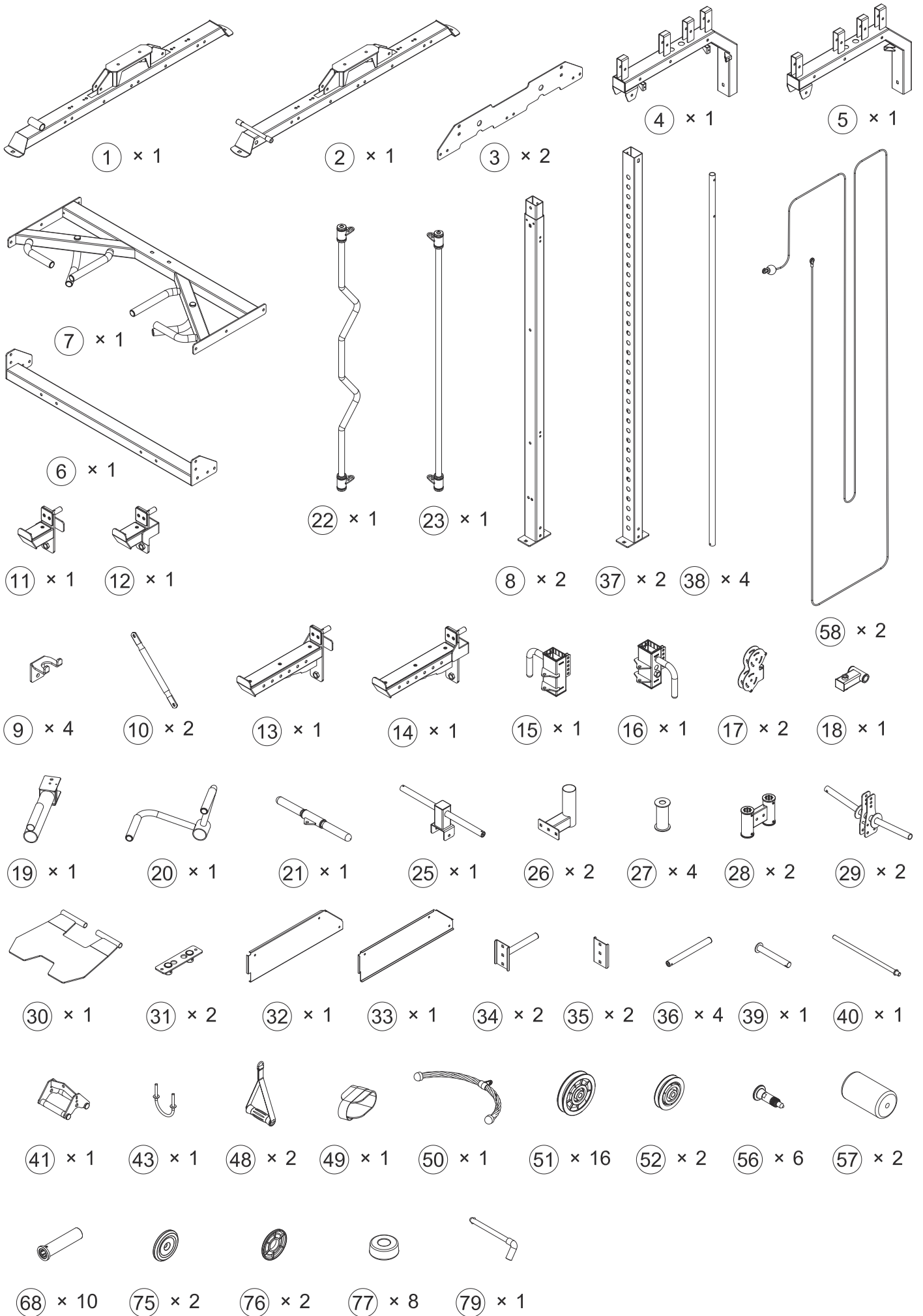

HARDWARE PACK

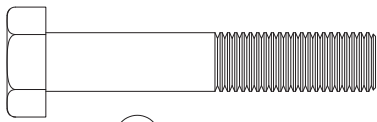

81 × 4

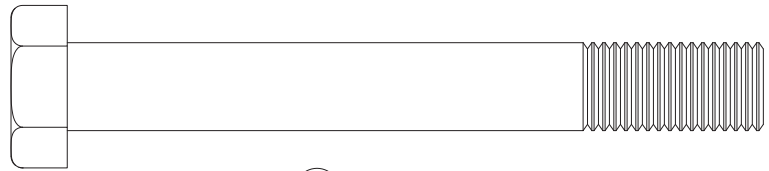

90 × 3



82 × 4

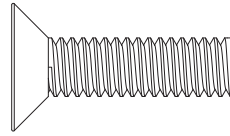

93 × 2

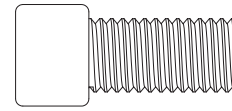

94 × 16

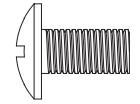

95 × 6

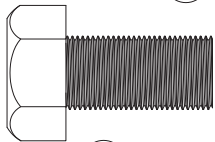

83 × 4

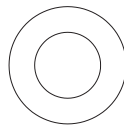

97 × 32

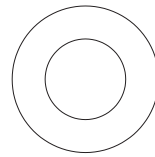

98 × 132

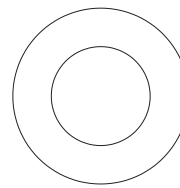

99 × 6

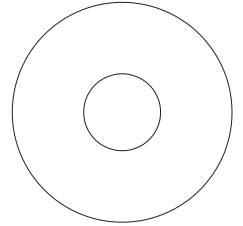

100 × 22

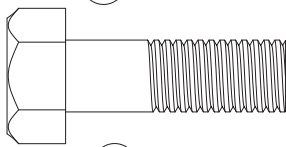

84 × 2

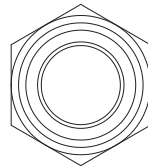

103 × 3

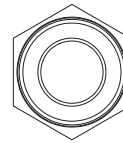

102 × 68



101 × 16

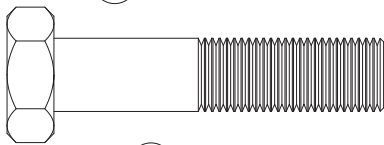

85 × 12

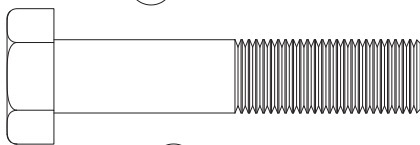

86 × 10



104 × 4

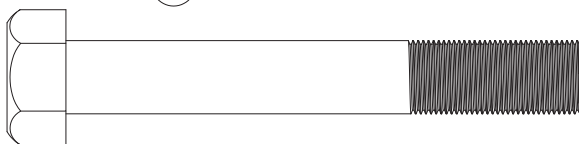

87 × 6

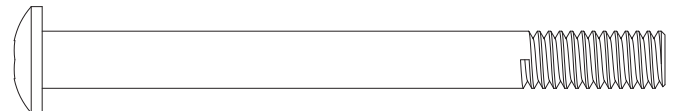

106 × 8

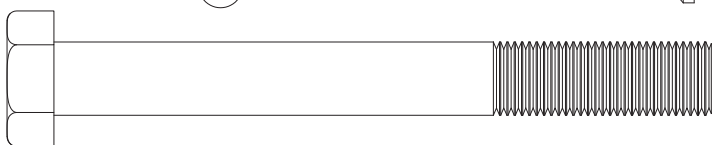

88 × 20

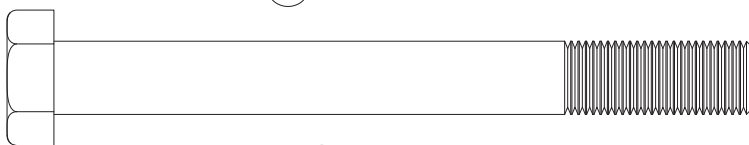
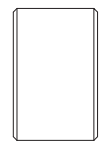
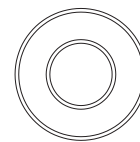

89 × 12

78 × 8

mm

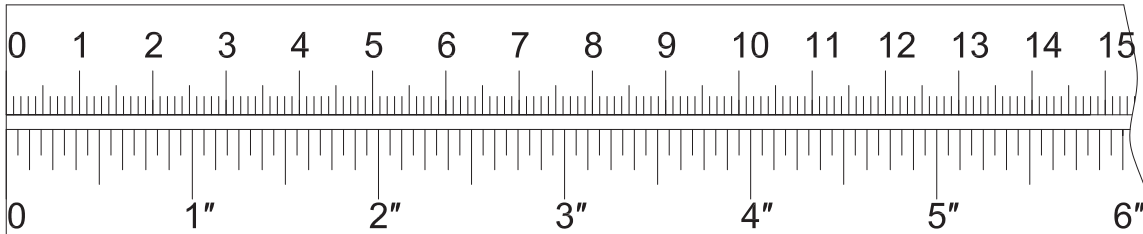

HARDWARE PACK

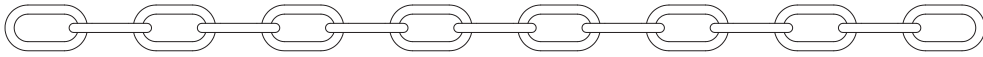

54 × 1

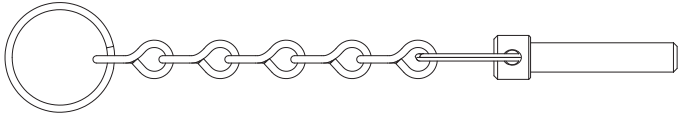

47 × 1

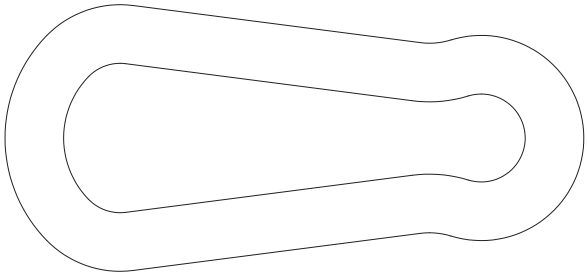

53 × 2

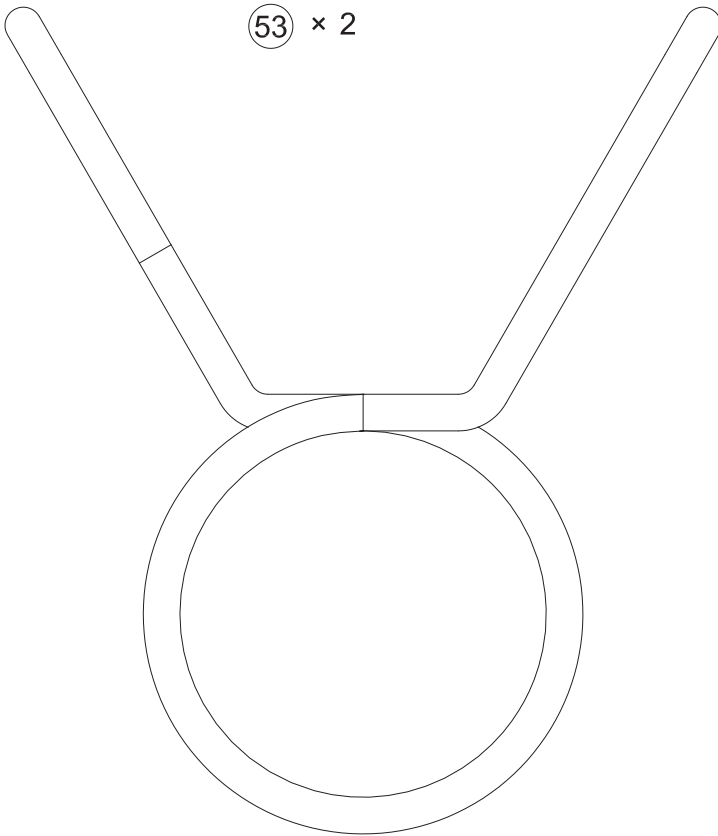

55 × 10

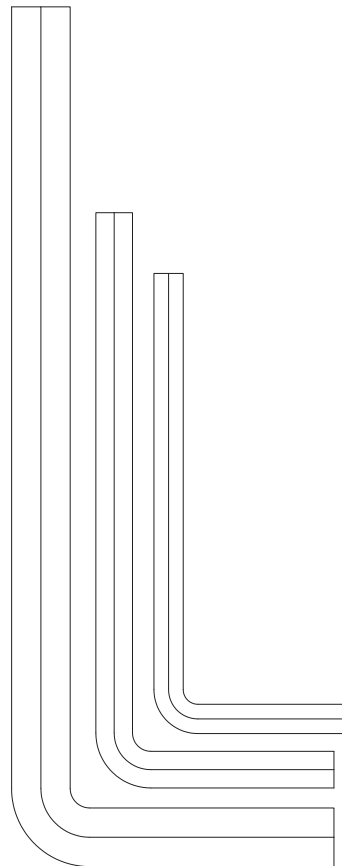

4# × 1

5# × 1

8# × 1

mm

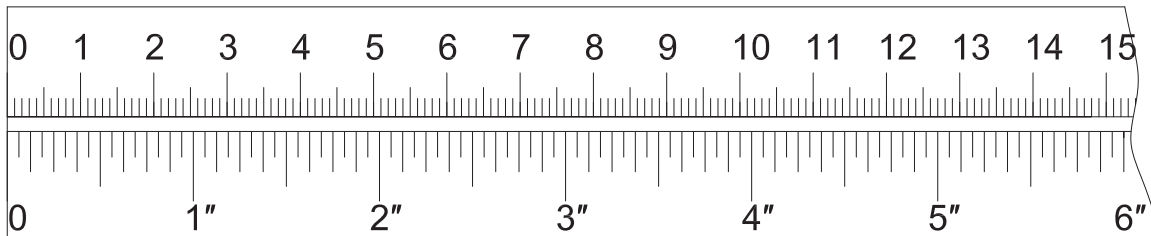







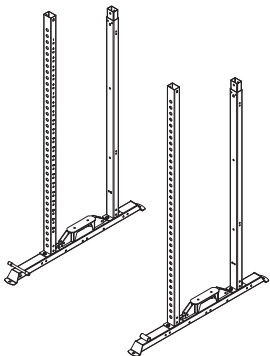
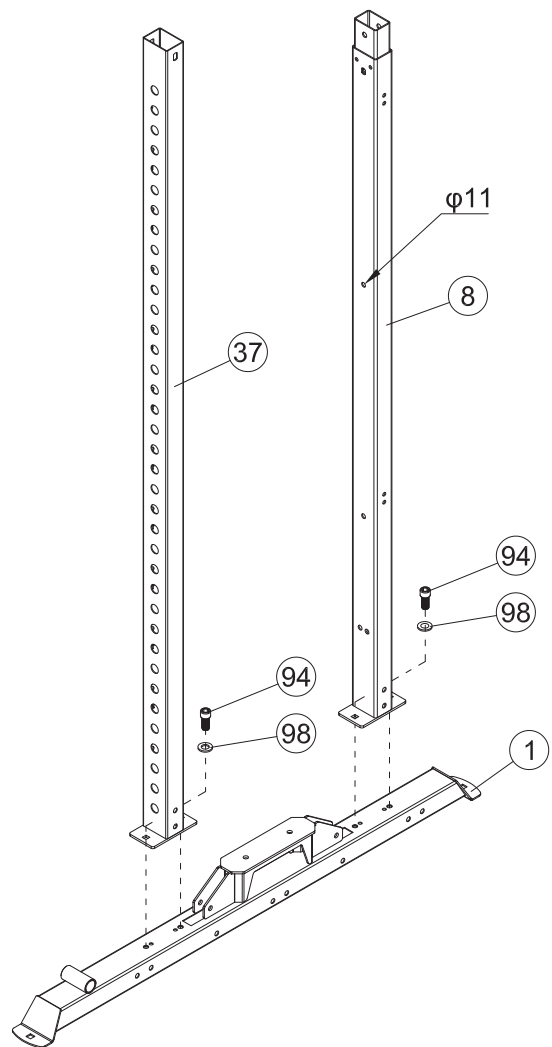
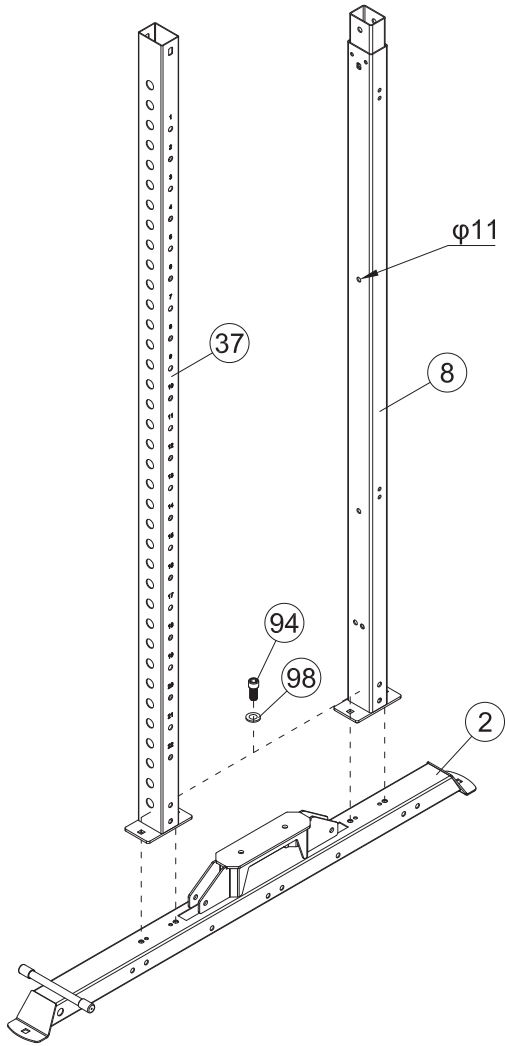
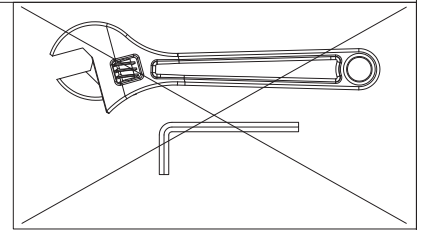

× 8 M10×20

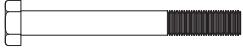
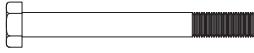

× 8 φ10



#1	BOX 3
#2	BOX 3
#8	BOX 1
#37	BOX 1

- (88)  × 8 M10×90
- (89)  × 8 M10×95
- (102)   × 16 M10
- (98)   × 24 φ10
- (100)   × 8 φ30×φ10.5×2.5

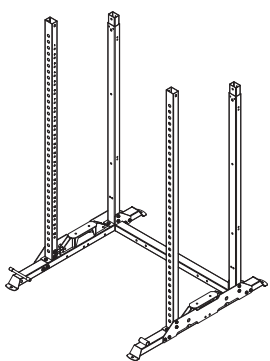
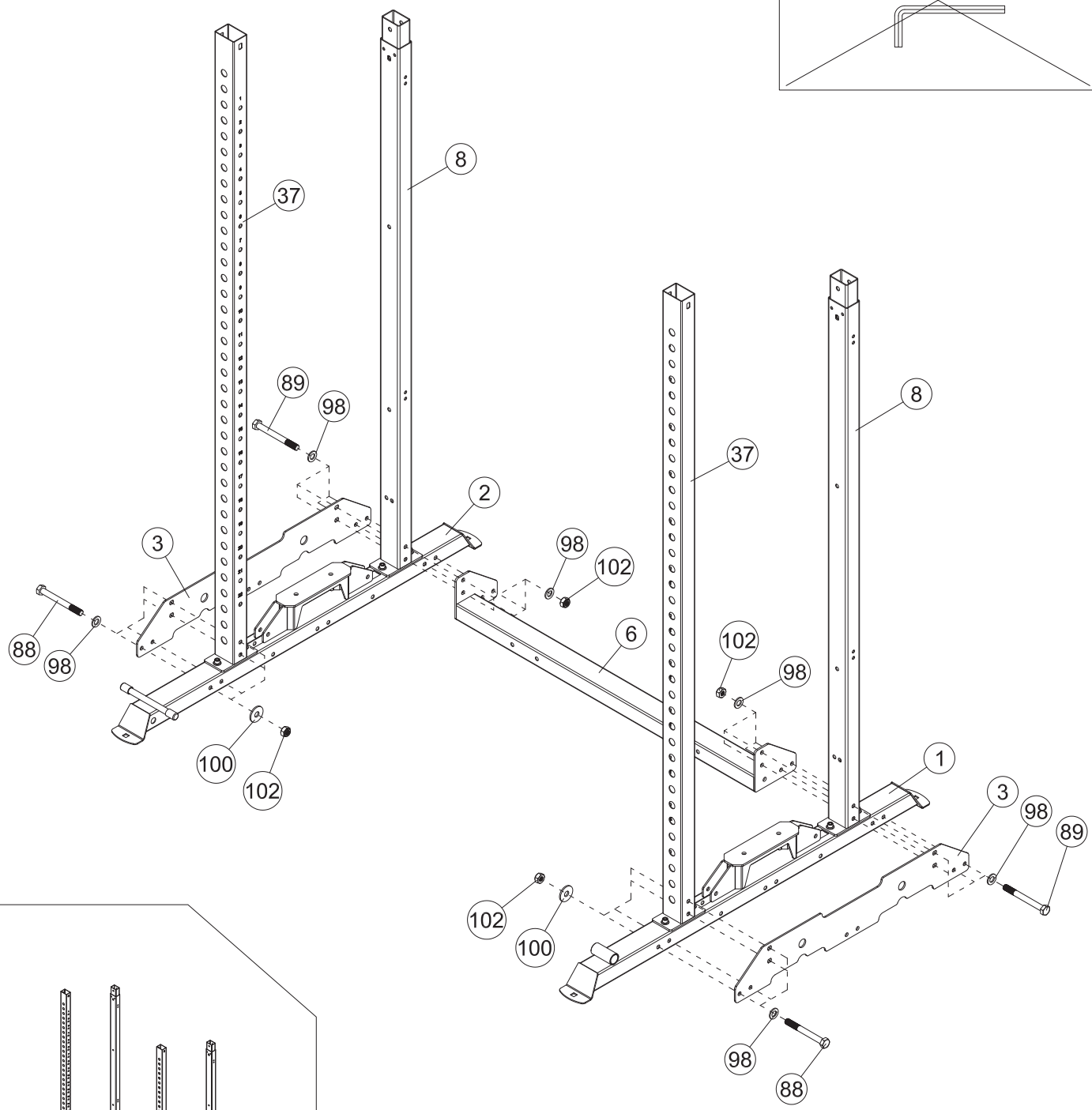
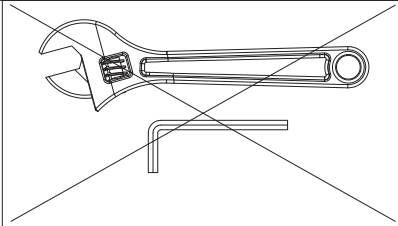

#3	BOX 2
#6	BOX 3

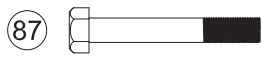

× 4 M10×70



× 12 φ10

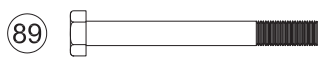

× 2 M10×95



× 6 M10

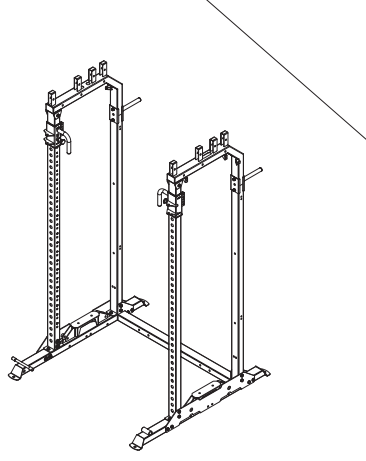
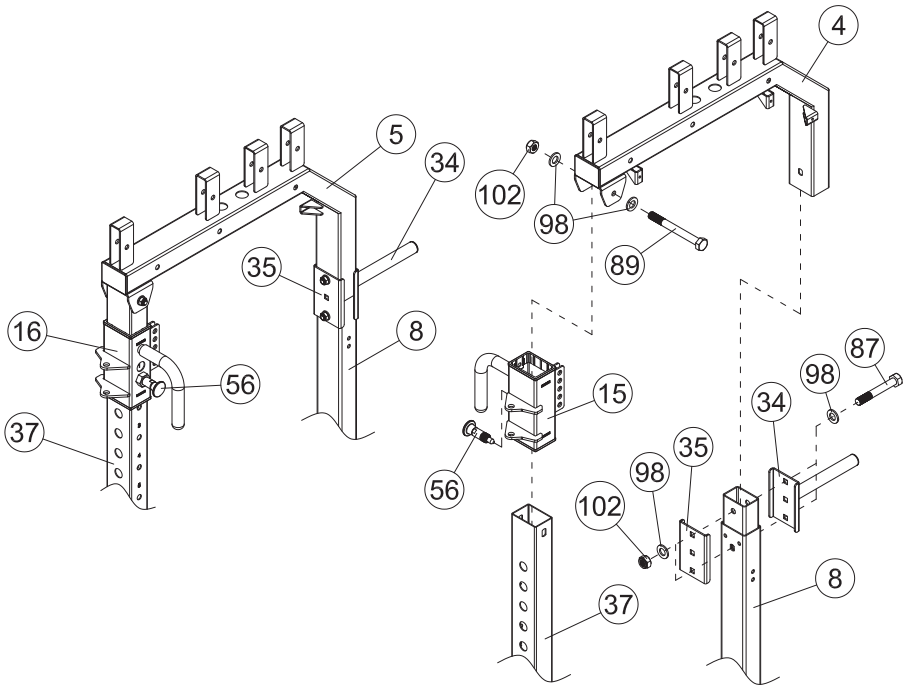
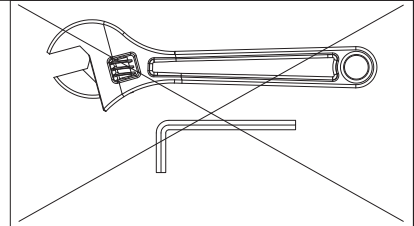





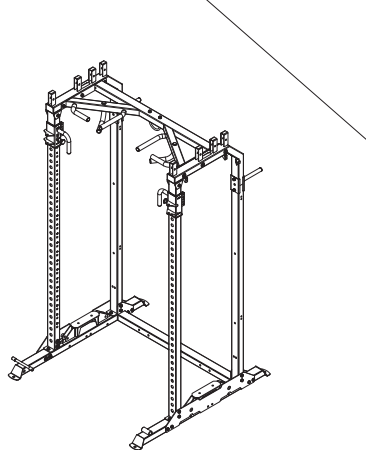
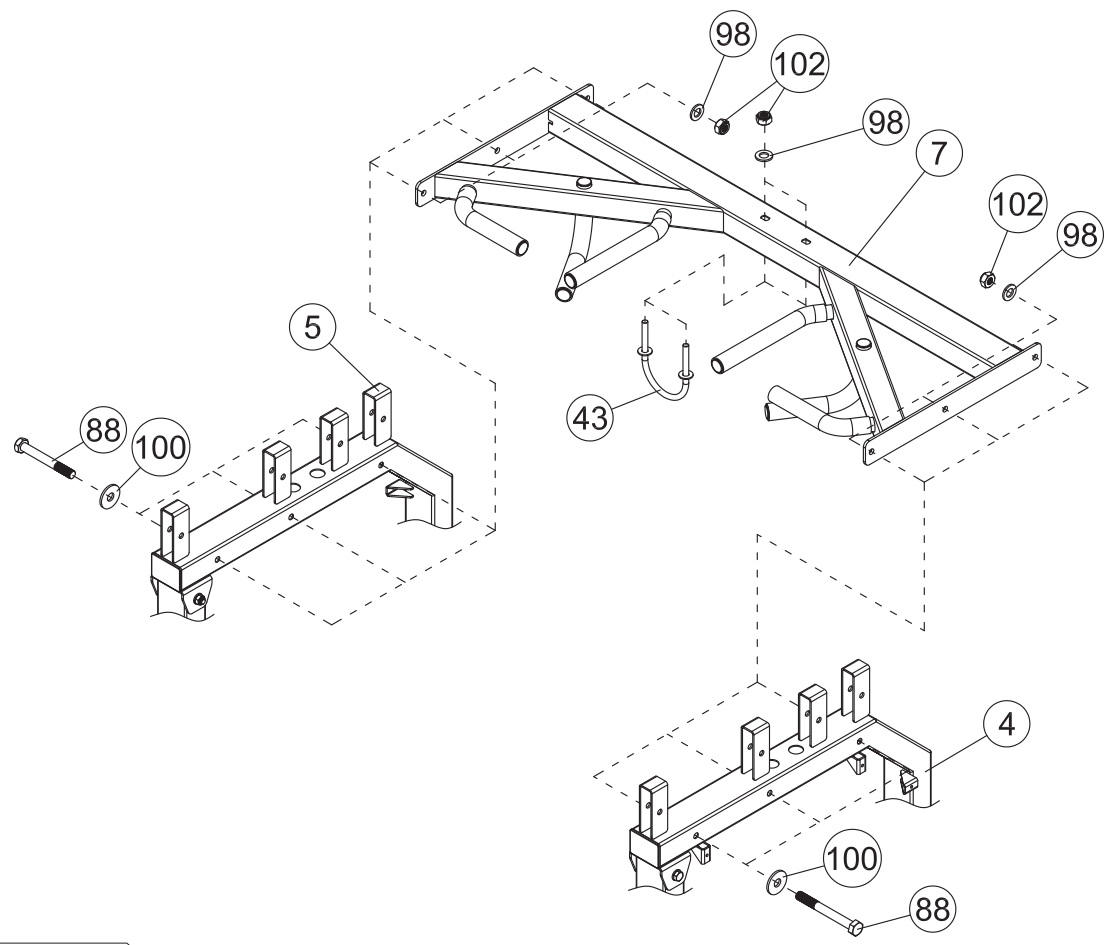
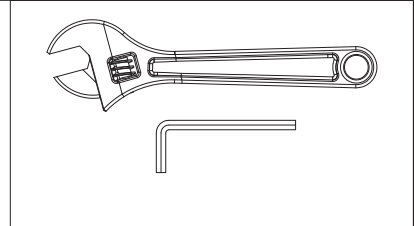





#4	BOX 4
#5	BOX 4
#15	BOX 5
#16	BOX 5
#34	BOX 5
#35	BOX 5
#56	BOX 5

- (88) 
× 6 M10×90
(100) 
× 6 φ30×φ10.5×2.5
- (98) 
× 8 φ10
(102) 
× 8 M10







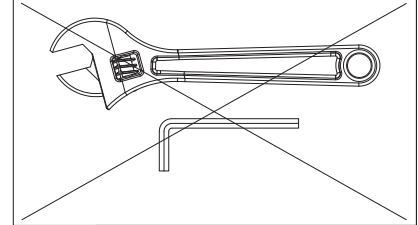



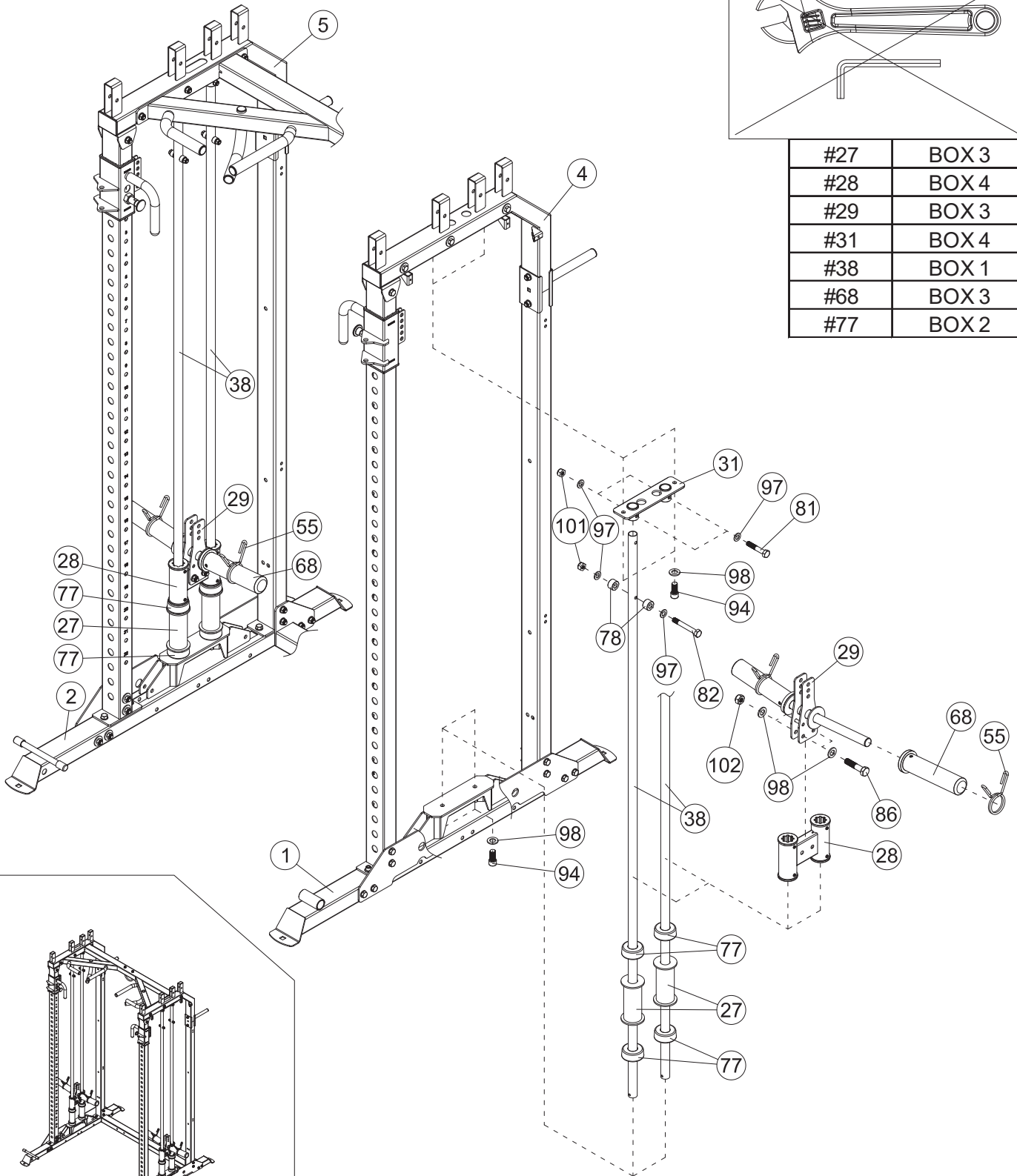

#7	BOX 2
#43	BOX 5

- 78   × 8 φ18×φ9×10
- 81  × 4 M8×45
- 82  × 4 M8×60
- 86  × 4 M10×50
- 94  × 8 M10×20
- 97  × 16 φ8
- 98  × 16 φ10
- 101  × 8 M8
- 102  × 4 M10
- 55  × 4 φ49







#27	BOX 3
#28	BOX 4
#29	BOX 3
#31	BOX 4
#38	BOX 1
#68	BOX 3
#77	BOX 2

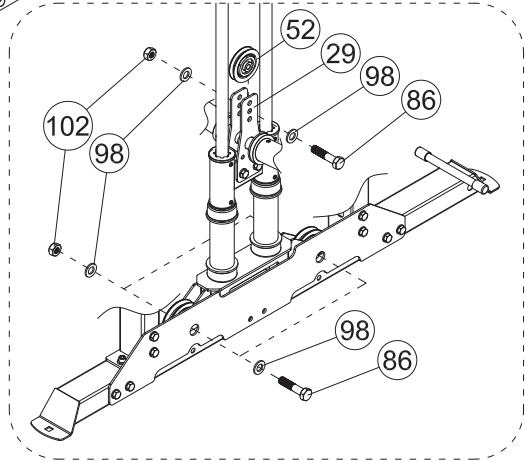
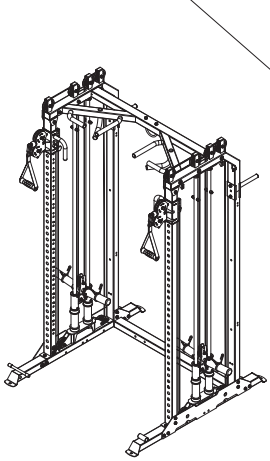
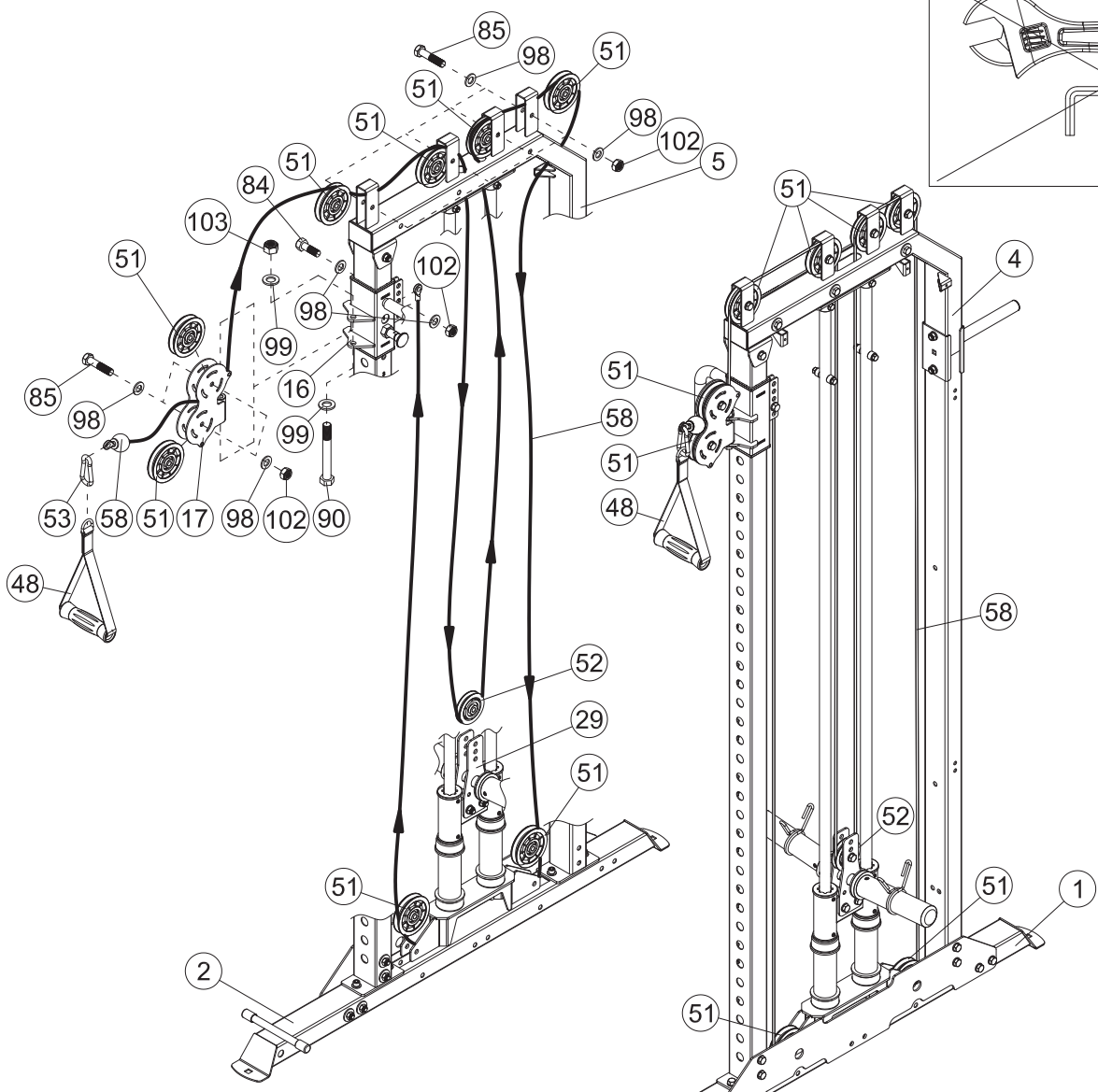
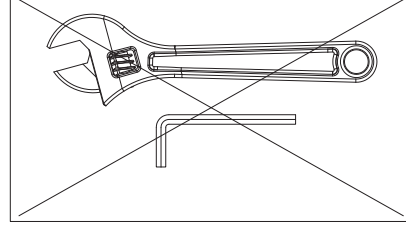

- 84  × 2 M10×30
- 85  × 12 M10×45
- 86  × 6 M10×50
- 90  × 2 M12×95
- 98  × 40 φ10
- 99  × 4 φ12
- 102  × 20 M10
- 103  × 2 M12
- 53  × 2 φ8

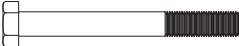

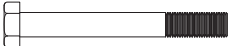
#17	BOX 2
#48	BOX 2
#51	BOX 2
#52	BOX 5
#58	BOX 5

- | | | | | | | | |
|----|---|------|--------|----|---|-----|---------------|
| ⑧⑧ |  | × 4 | M10×90 | ⑩⑩ |  | × 4 | φ30×φ10.5×2.5 |
| ⑩④ |  | × 4 | M10×85 | ⑩② |  | × 8 | M10 |
| ⑨⑧ |  | × 12 | φ10 | | | | |

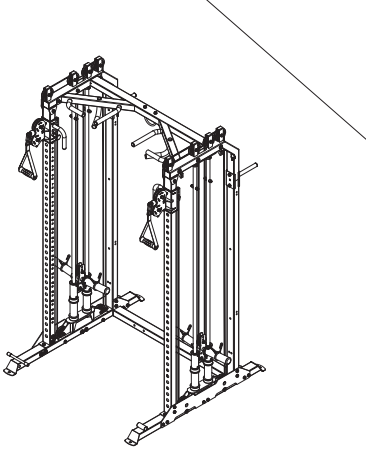
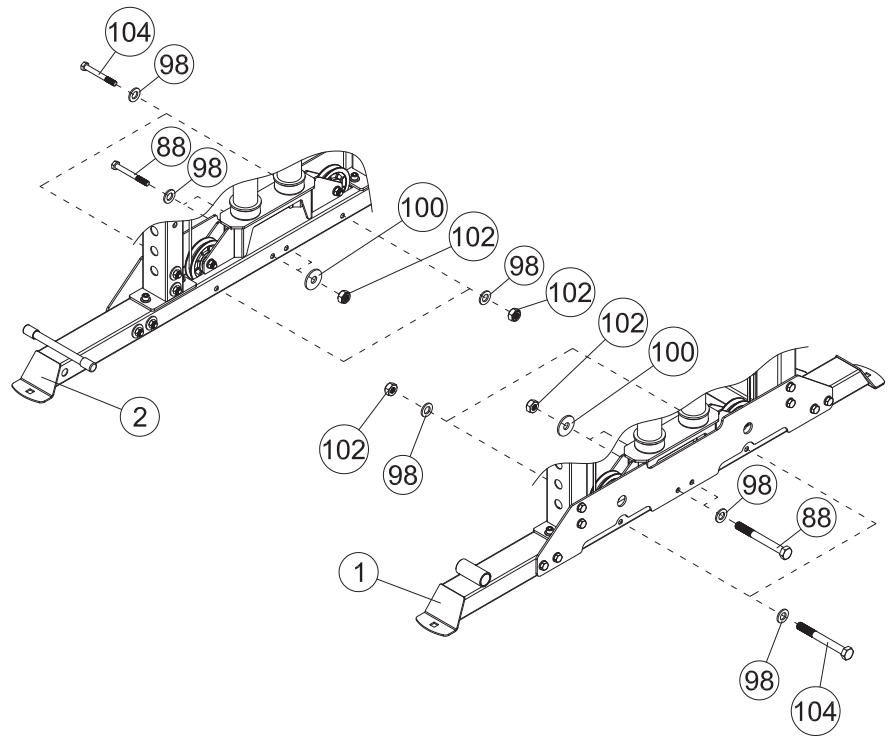
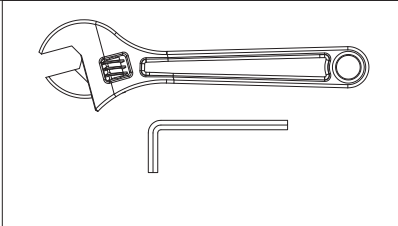

7-A

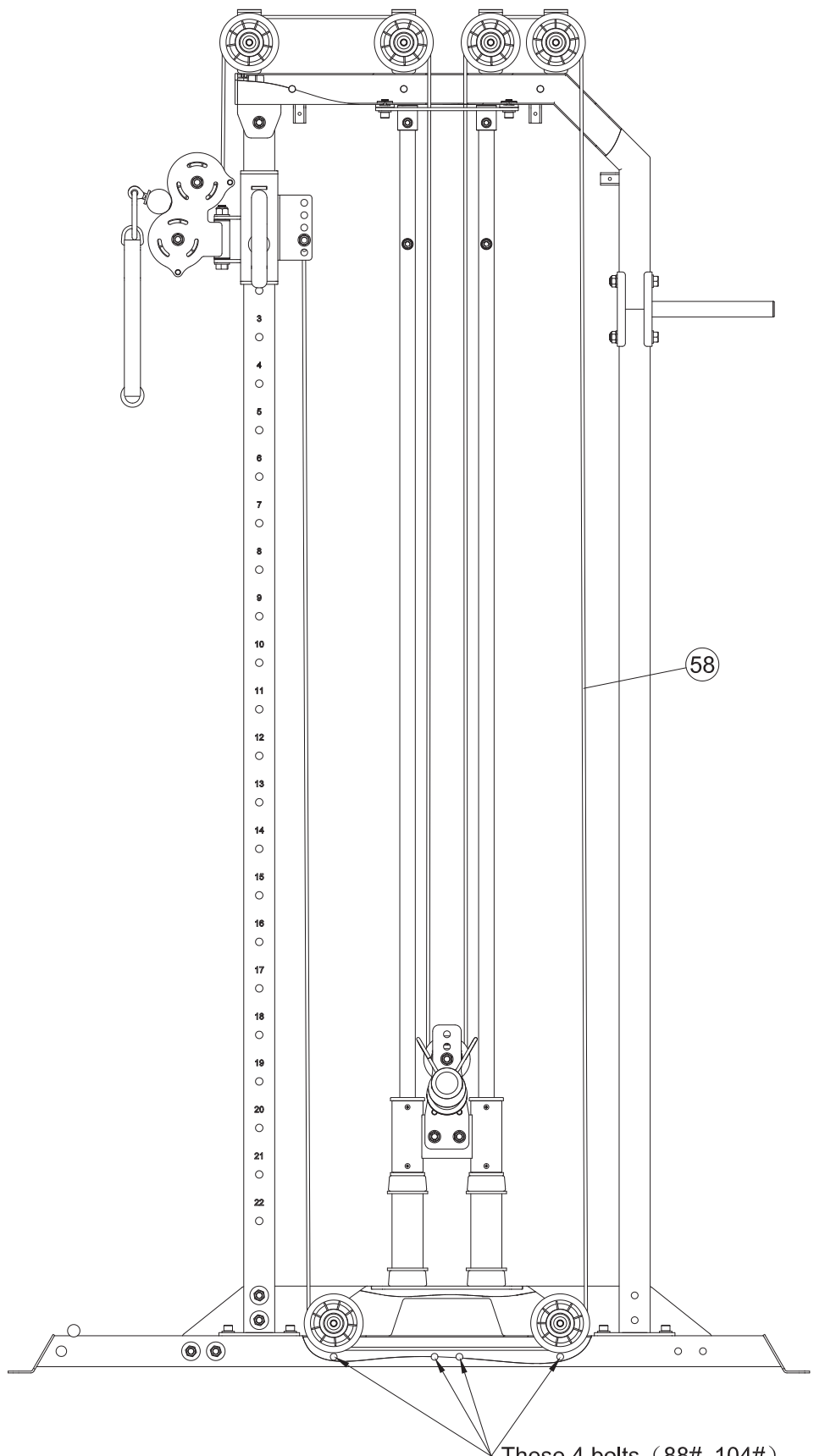

58

These 4 bolts (88# 104#)
should be under the cable (58#)

7-B

87  × 2 M10×70

98   × 8 φ10

88  × 2 M10×90

100   × 4 φ30×φ10.5×2.5

89  × 2 M10×95

102   × 6 M10

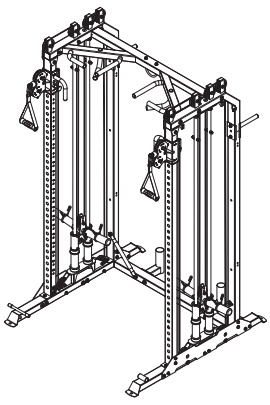
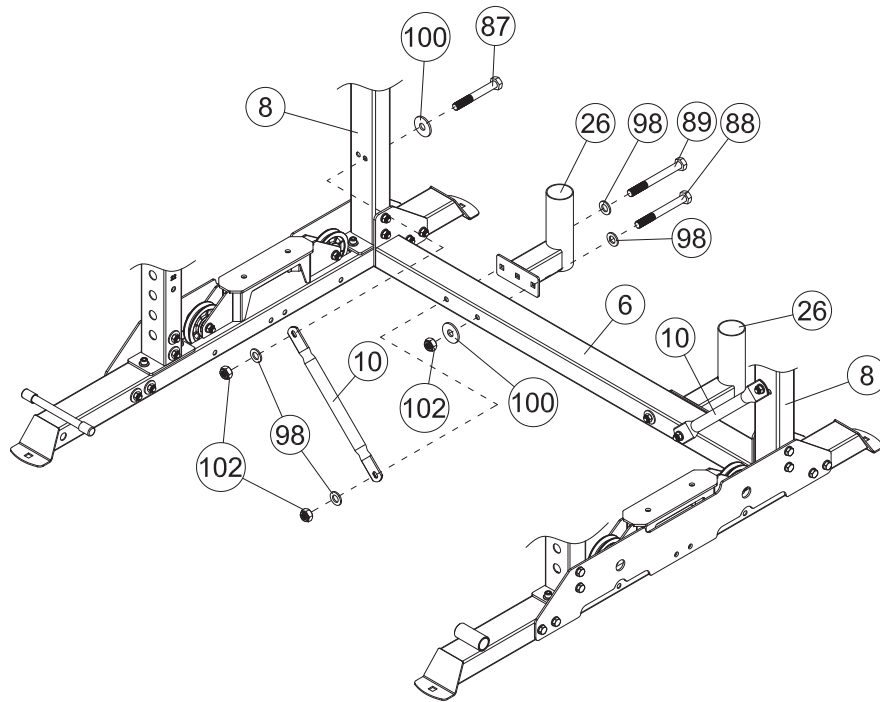
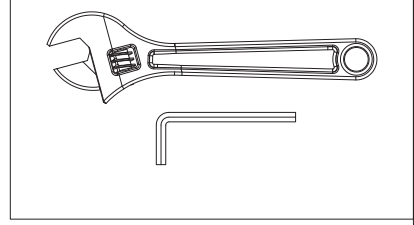

#10	BOX 4
#26	BOX 5



× 4 M10×20

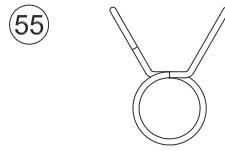

× 6 φ49



× 6 M6×12



× 4 φ10

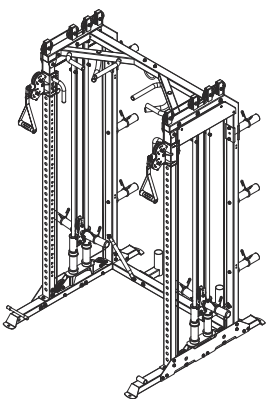
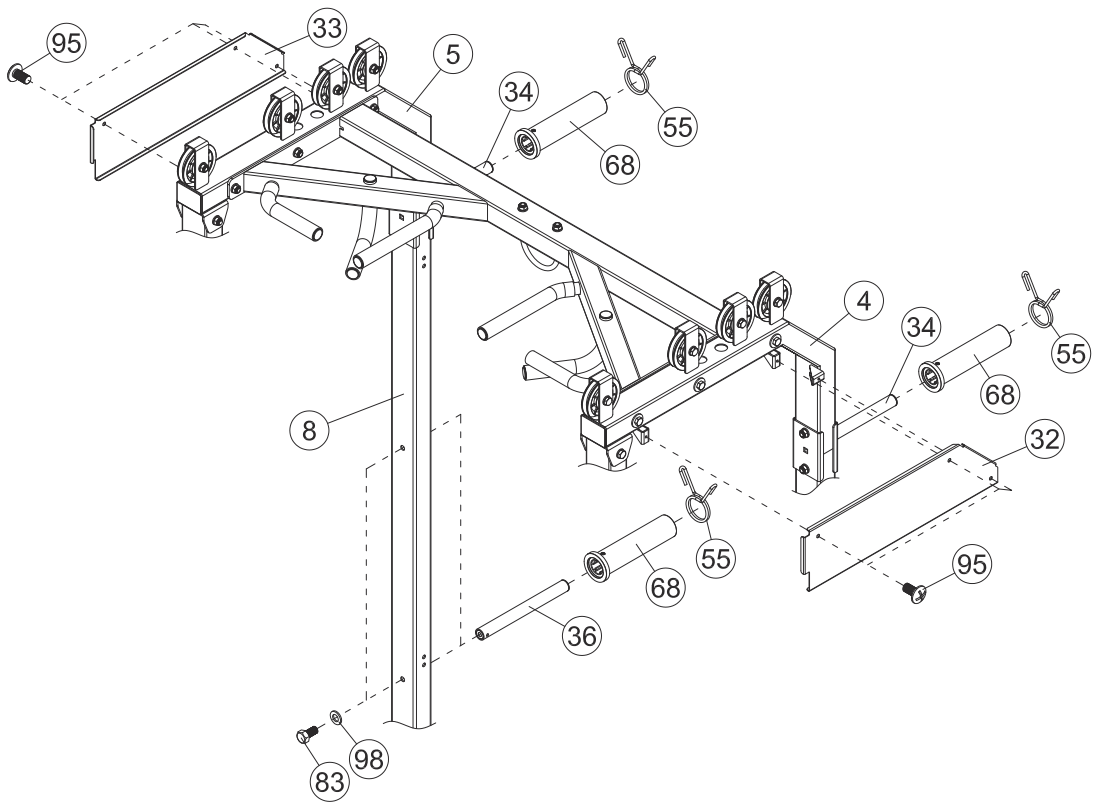
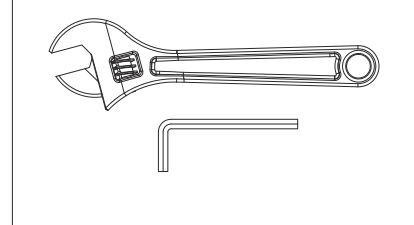

#32	BOX 3
#33	BOX 3
#36	BOX 5
#68	BOX 3



× 1



× 2 φ12

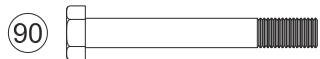

× 1 M12×95



× 1 M12

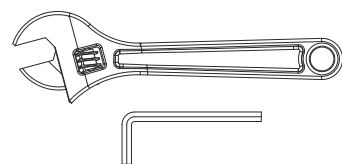

#18	BOX 3
#19	BOX 4
#20	BOX 5
#30	BOX 4
#39	BOX 5
#40	BOX 4

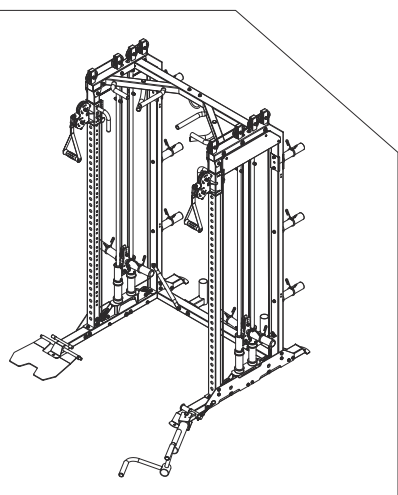
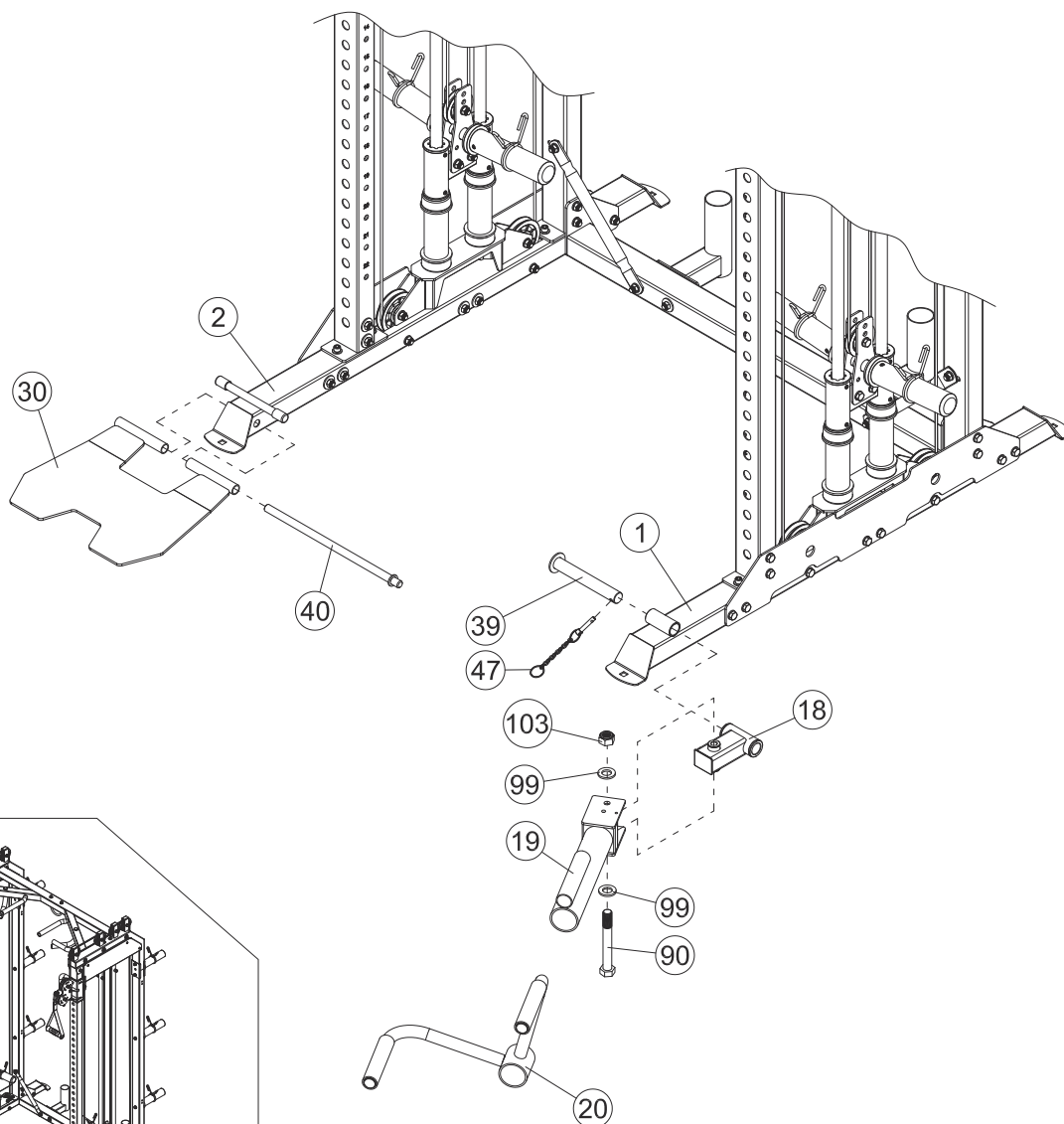

93



× 2 M8×30

#11	BOX 2
#12	BOX 2
#13	BOX 2
#14	BOX 2
#25	BOX 3
#56	BOX 5
#57	BOX 2
#75	BOX 5
#76	BOX 5
#79	BOX 5

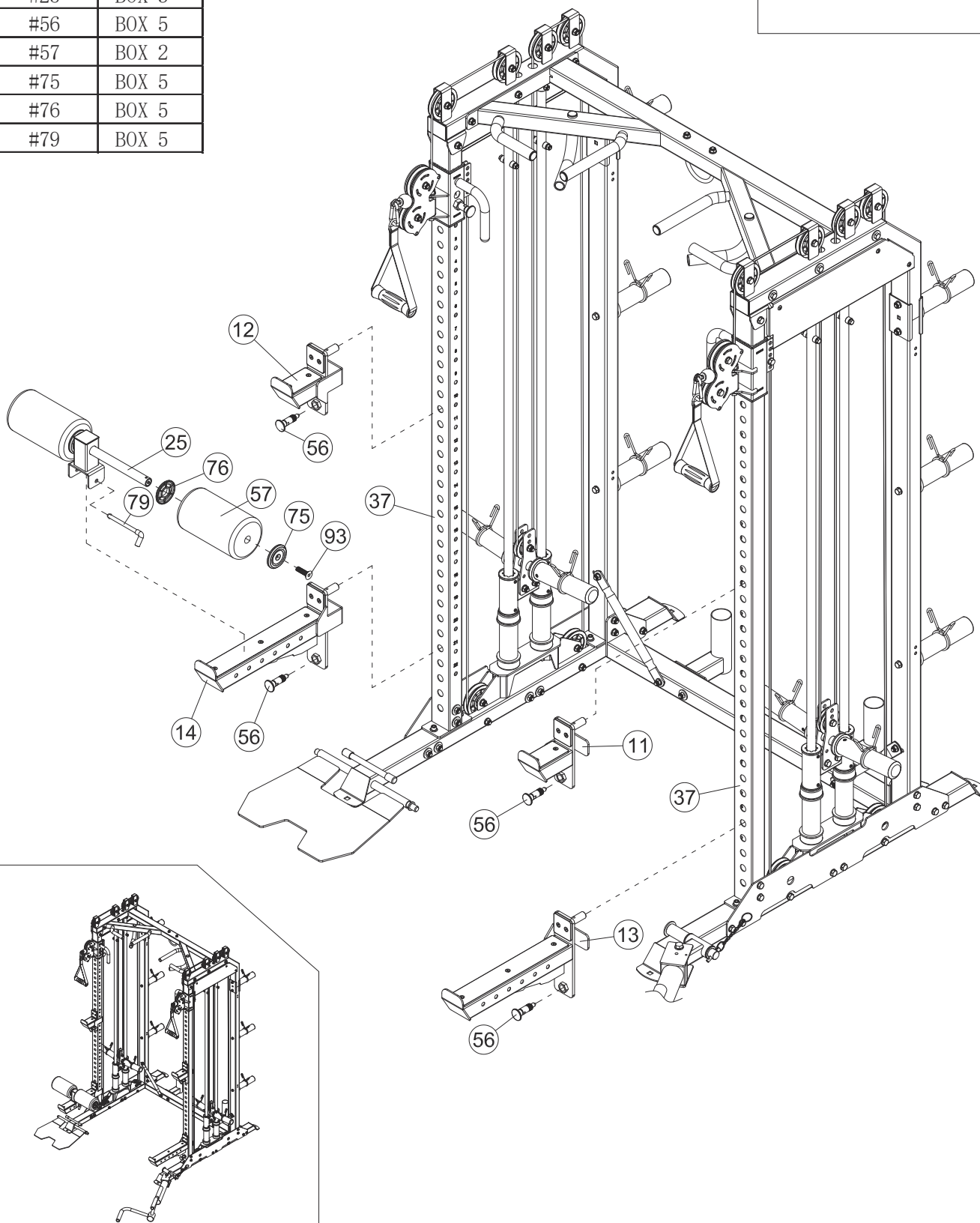
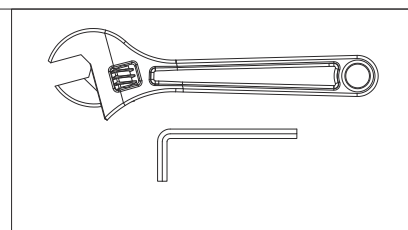

97   × 16 φ8

54  × 1

101   × 8 M8

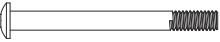
106  × 8 M8×85

#9	BOX 5
#21	BOX 4
#22	BOX 3
#23	BOX 3
#41	BOX 5
#49	BOX 2
#50	BOX 5

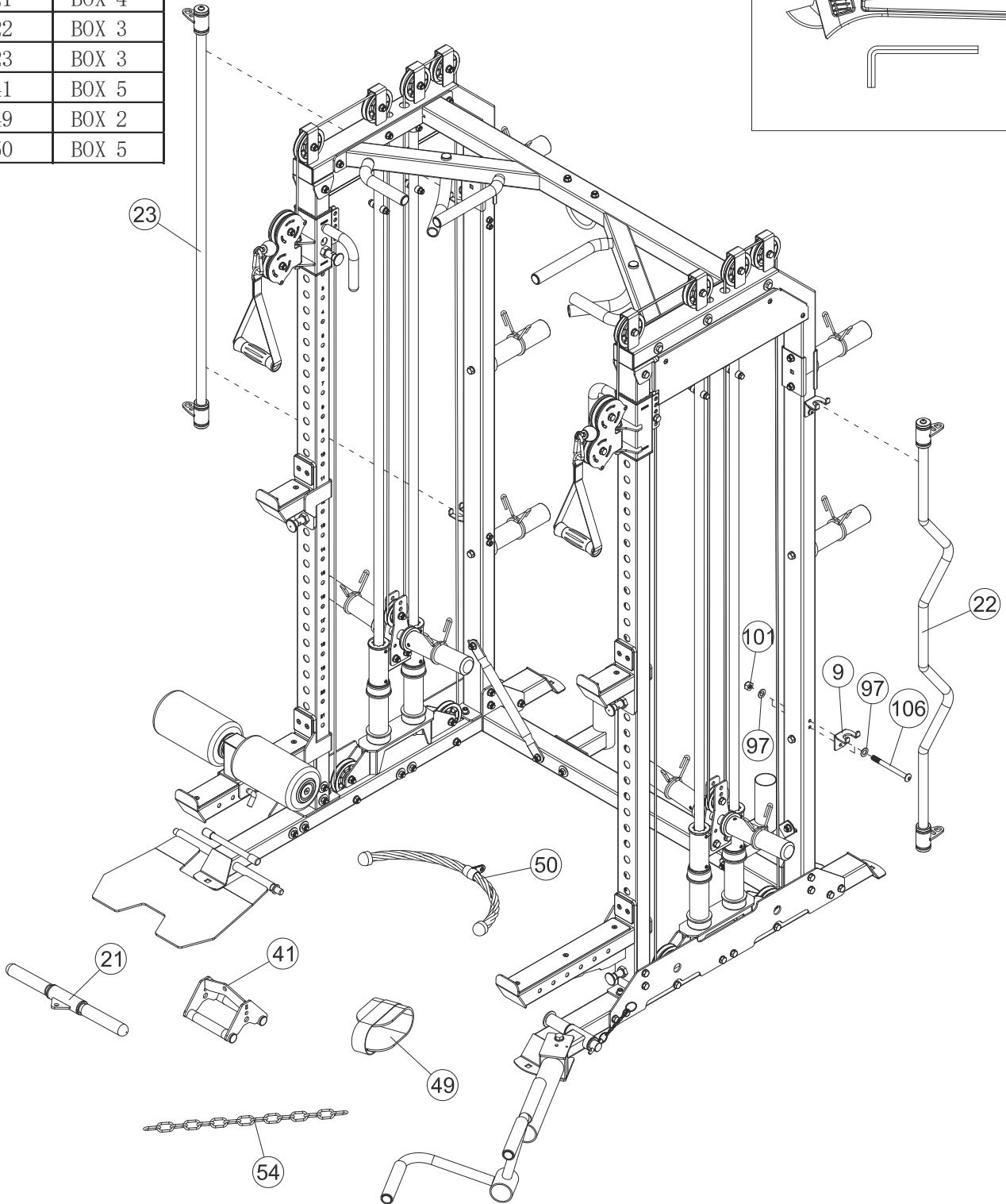
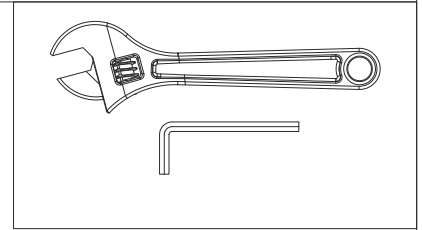

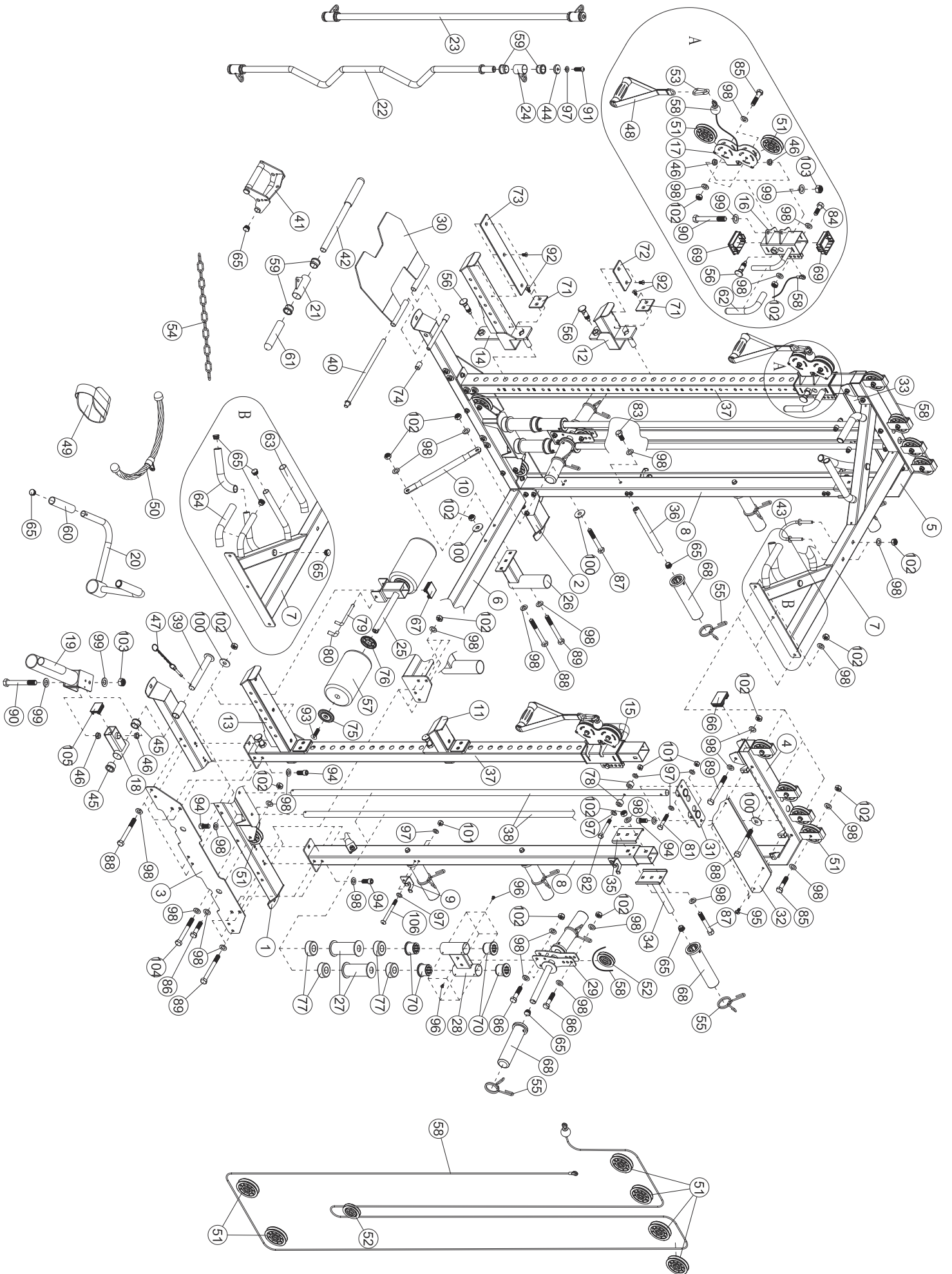

PARTS LIST

KEY NO.	PART DESCRIPTION	SPEC	QTY
1	Base Frame L		1
2	Base Frame R		1
3	Base Bracket	855×130×4	2
4	Top Frame L		1
5	Top Frame R		1
6	Connecting Frame Rear		1
7	Connecting Frame Top		1
8	Rear Post		2
9	Handle Store	50×50×50×4	4
10	Connecting Rod	φ25×1.5×(363)	2
11	Short Safety Rack L		1
12	Short Safety Rack R		1
13	Long Safety Rack L		1
14	Long Safety Rack R		1
15	Sliding Frame L		1
16	Sliding Frame R		1
17	Pulley Case		2
18	Spacer		1
19	Rotating Frame		1
20	Handle		1
21	Small Grip Frame		1
22	Cambered Bar (attachment)		1
23	Straight Bar (attachment)		1
24	Rotating Frame for Bar		4
25	FOAM Frame		1
26	Barbell Socket		2
27	Support Frame		4
28	Sliding Frame Rear		2
29	Weight Support		2
30	Foot Pedal Set		1

PARTS LIST

KEY NO.	PART DESCRIPTION	SPEC	QTY
31	Guide Rod Support		2
32	Cover L	560×152×1.5	1
33	Cover R	560×152×1.5	1
34	Weights Stow Rod		2
35	Bracket	120×71×13×3	2
36	Weights Stow Rod		4
37	Front Post		2
38	Guide Rod Rear	φ25×1900	4
39	Rotating Shaft		1
40	Long Latch		1
41	V-type Handle		1
42	Handle	φ25×1.5×400	1
43	U-type Hook		1
44	Bushing	φ38×φ9×8	4
45	Bushing	φ38×φ34×φ25×22	2
46	Bushing	φ25×φ20×φ12.2×10	6
47	Pop Pin		1
48	Handle		2
49	Ankle Strap		1
50	Rope		1
51	Pulley	φ96	16
52	Small Pulley	φ75	2
53	Hook	φ8	2
54	Joint Chain		1
55	Spring Clip	φ49	10
56	Moving Lock Pin		6
57	FOAM	φ125×φ22×215	2
58	Double Pull Cable	L=8635mm	2
59	Bushing	φ38×φ34×φ27×26	10
60	Dips Handle	φ23×150	2
61	Dips Handle	φ24×150	2

PARTS LIST

KEY NO.	PART DESCRIPTION	SPEC	QTY
62	Dips Handle	φ24×φ18×227	2
63	Dips Handle	φ30×φ23×250	2
64	Dips Handle	φ23×200	4
65	Round End Cap	φ25	24
66	Rectangular End Cap	70×50	2
67	Rectangular End Cap	□50	1
68	Olympic Sleeve	φ50×210	10
69	Slide Guide	□60×80×2×□50×70	4
70	Guides	φ55×φ46×φ27×41	8
71	Rack Liner	65×65×5	4
72	Rack Liner	115×65×5	2
73	Rack Liner	410×65×5	2
74	Rubber Stopper	φ20×φ16×29	2
75	FOAM End Cover	φ70×φ9×8.5	2
76	FOAM Inner Baffle	φ70×φ26×9.5	2
77	Rubber Stopper	φ62×φ24.5×25	8
78	Limit Spacer	φ18×φ9×10	8
79	L Spring Pin	φ10×125	1
80	Rubber Spacer	φ13×φ9.5×58	1
81	Hex Bolt	M8×45	4
82	Hex Bolt	M8×60	4
83	Hex Bolt	M10×20	4
84	Hex Bolt	M10×30	2
85	Hex Bolt	M10×45	12
86	Hex Bolt	M10×50	10
87	Hex Bolt	M10×70	6
88	Hex Bolt	M10×90	20
89	Hex Bolt	M10×95	12
90	Hex Bolt	M12×95	3
91	Allen Bolt	M8×25	4
92	Allen Bolt	M6×12	18

PARTS LIST

KEY NO.	PART DESCRIPTION	SPEC	QTY
93	Allen Bolt	M8×30	2
94	Allen Bolt	M10×20	16
95	Screw	M6×12	6
96	Screw	ST4.0×9	16
97	Washer	8	36
98	Washer	10	132
99	Washer	12	6
100	Washer	φ30×φ10.5×2.5	22
101	Hex Nut	M8	16
102	Hex Nut	M10	68
103	Hex Nut	M12	3
104	Hex Bolt	M10×85	4
105	Rectangular End Cap	40×50	1
106	Allen Bolt	M8×85	8
	Allen wrench	4#	1
	Allen wrench	5#	1
	Allen wrench	8#	1